

PIANTA ROTONDA / ROUND SECTION



Disponibili a 1, 2 o 3 livelli, con combinazioni a scelta di lenti rosse, gialle, verdi, blu, trasparenti e opalescenti. Ogni livello è illuminato da un L.E.D. bianco ad alta intensità e basso consumo. Le torrette a un livello con lente trasparente o opalescente portano un Led RGB.

- L.E.D. ad alta intensità luminosa e basso consumo energetico
- Lenti di diffusione delle luci e telaio in resine polimeriche termo-resistenti
- Telaio cromato o nero
- Facile montaggio

PIANTA ELLITTICA / OVAL SECTION



Round-section or Elliptic-section tower lights are available in combination of 1, 2 or 3 tiers; combinations can be chosen among red, yellow, green, blue, clear and opal lenses.

Each tier is illuminated by one bright low consumption white L.E.D. .

Single-level tower lights combined with clear or opal lenses can house one RGB L.E.D..

- *High-intensity, energy-saving, efficient L.E.D.s*
- *The lenses and the chassis are molded in heat-resistant polymers*
- *Chrome or black frame available*
- *Easy installation*

DATI TECNICI / TECHNICAL SPECS

Alimentazione / Power supply:	12Vcc /12Vdc
Assorbimento / Current draw:	Led bianchi: 75 mA (1 modulo/1 tier) - 150 mA (2 moduli/2 tiers) - 225 mA (3 moduli/3 tiers); Led RGB: 105 mA max
Peso / Weight:	Pianta rotonda / Round section: 0,091 kg (1 livello / 1 tier) - 0,134 kg (2 livelli / 2 tiers) - 0,177 kg (3 livelli / 3 tiers) Pianta ellittica / Oval section: 0,105 kg (1 livello / 1 tier) - 0,150 kg (2 livelli / 2 tiers) - 0,200 kg (3 livelli / 3 tiers)
Potenza luminosa / Light Power:	180 lumen x 1-2-3 moduli / tiers

DIMENSIONI OVERALL DIMENSIONS

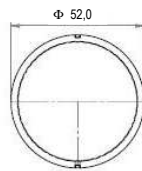
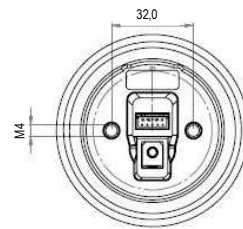
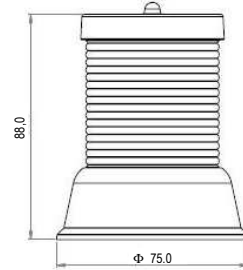
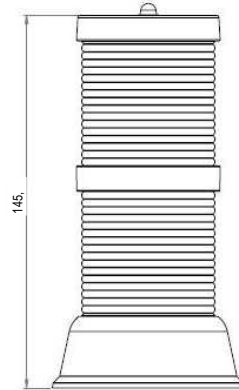
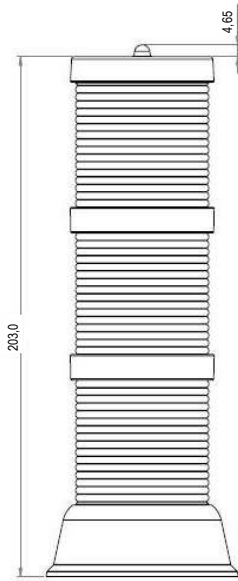

Dimensioni della lente
Lens Size

Torrette a pianta rotonda
Round section Towers

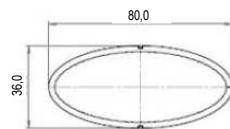
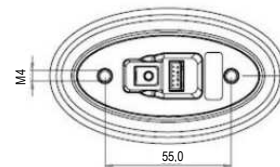
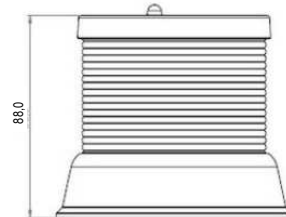
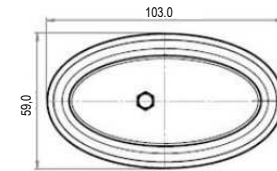
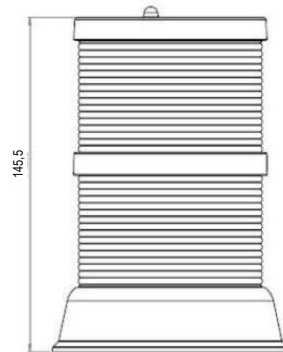
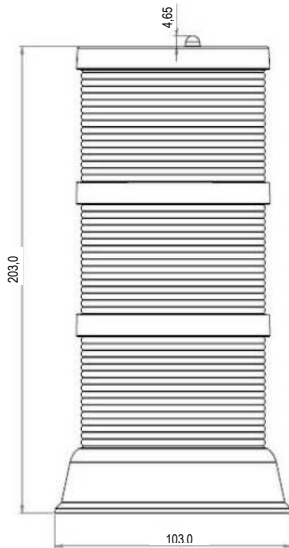

Dimensioni della lente
Lens Size

Torrette a pianta ellittica
Oval section Towers

MONTAGGIO / INSTALLATION



Fissaggio meccanico / Mounting the beacon

Fissare la torretta alla cima della macchina mediante i 2 fori filettati M4 posizionati sull'asse della base, a 55mm l'uno dall'altro.

Non essendo possibile prevedere lo spessore del mobile, le viti M4 necessarie al fissaggio non sono fornite.

 Non serrare le viti con forza superiore a 1,2 nM.

The tower beacon must be fixed to the machine top by the 2 M4 threaded bores at the foot of the lower tier; distance between the two bores is 55mm. It is not possible to pre-determine the thickness of the machine cabinet, therefore the M4 screws are not supplied.

 Do not torque the screws to more than 1,2 nM.



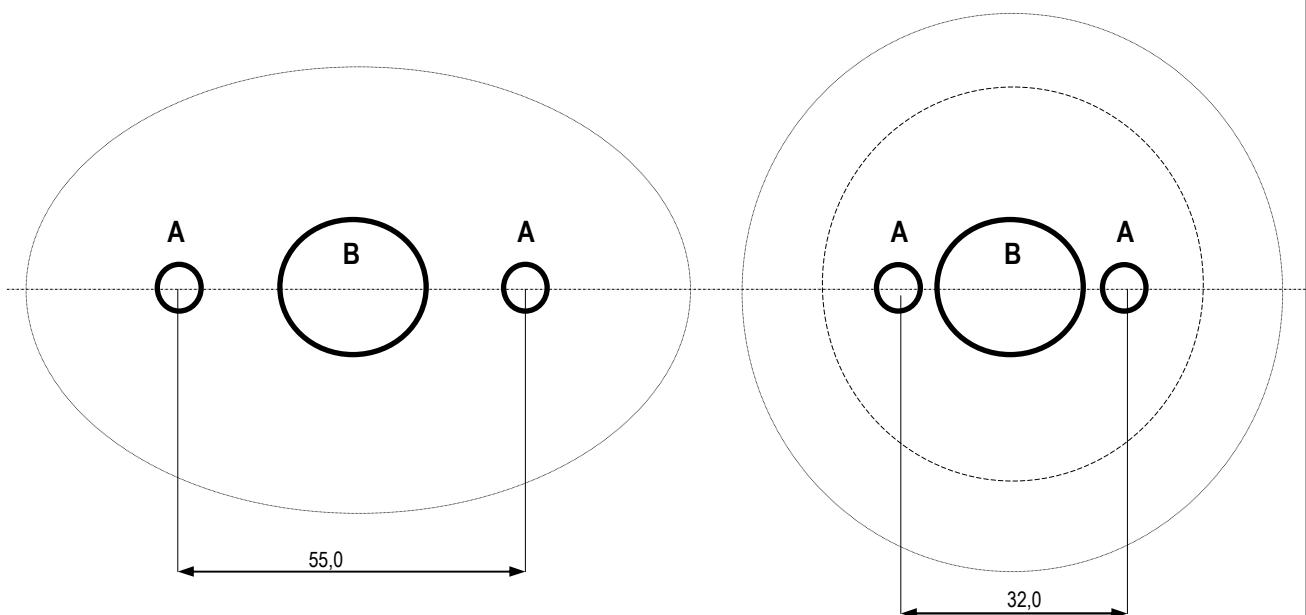

A = fori Φ 4,5mm su pannello per viti fissaggio M4 / panel holes Φ 4,5mm for M4 tightening screws

B = foro Φ 15mm per passaggio del cavo elettrico / pass-through 15mm hole for electrical wiring

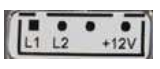

Collegamenti elettrici / Electrical connections

Collegare l'alimentazione tramite la presa Molex 4poli	<i>Power the Tower through the 4pin Molex socket</i>
L'alimentazione +12V va fornita al pin 1	<i>Connect +12V to pin 1</i>
I rimanenti pin vanno pilotati a seconda del modello di Torretta luminosa, come da tabella seguente:	<i>Drive the three remaining pins according to the type of Tower, as per table below::</i>

Modulo singolo RGB: pin 2 = blu - pin 3 = verde - pin 4 = rosso		<i>RGB single tier: pin 2 = blue - pin 3 = green - pin 4 = red</i>
Modulo singolo 1 Led: pin 2 = vuoto - pin 3 = vuoto - pin 4 = GND		<i>Led single tier: pin 2 = void - pin 3 = void - pin 4 = GND</i>
Modulo doppio 2 Led: pin 2 = vuoto - pin 3 = GND - pin 4 = GND		<i>2-Led double tier: pin 2 = void - pin 3 = GND - pin 4 = GND</i>
Modulo triplo 3 Led: pin 2 = GND - pin 3 = GND - pin 4 = GND		<i>3-Led triple tier: pin 2 = GND - pin 3 = GND - pin 4 = GND</i>



Via Ca' Bianca 421
40024 Castel San Pietro Terme
(BO) - ITALY

Progettazione e produzione di sistemi di pagamento, accessori per videogames e macchine vending
Design and manufacture of payment systems, accessories for videogames and vending machines

Tel. + 39 051 944 300

Fax. + 39 051 944 594

<http://www.alberici.net>

info@alberici.net